

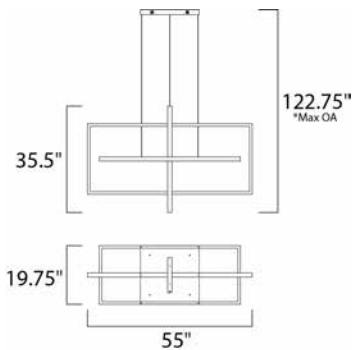

**PRODUCT DESCRIPTION**

Large scale rectangles of Brushed Champagne are positioned on different planes that intersect creating a novel lighting experience. Double rows of LED provide more than ample illumination adding to the value of this original design.



\*max overall height

**MEASUREMENTS**

DIMENSION : 55" L x 19.75" W x 35.5" H  
 MAX OAH : 122.75" OAH  
 HANGING WEIGHT : 35.2 lb

**LAMPING**

INPUT VOLTAGE : 120V  
 LUMENS : 3,575 Rated (2,500 Del.)  
 BULB : 3 x 123W LED PCB Integrated , 123W Total  
 BULB INCLUDED : (Integrated)  
 DIMMABLE : Triac CL  
 CRI : 90+ CRI  
 COLOR\_TEMP : 3000K

**FINISHES OPTION**

 Brushed Champagne

**MATERIAL**

Stainless Steel

**RATINGS**

cETLus  
 Dry Location



**ADDITIONAL**

ADJUSTABLE  
 RATED LIFE 25000 Hours  
 OPERATING TEMPERATURE:  
 -20°C (-4°F), 40°C (104°F)

Always consult a qualified electrician before installing any lighting product.